

High Pressure Booster Regulator/Air Tank

Increase factory air pressure by up to 2 times!

Air-only operation requires no power supply,
reduces heat generation and allows easy installation.

Part Number: SA-VBA43A-T04GN-Z-VBAT45HP-SV-MS-R

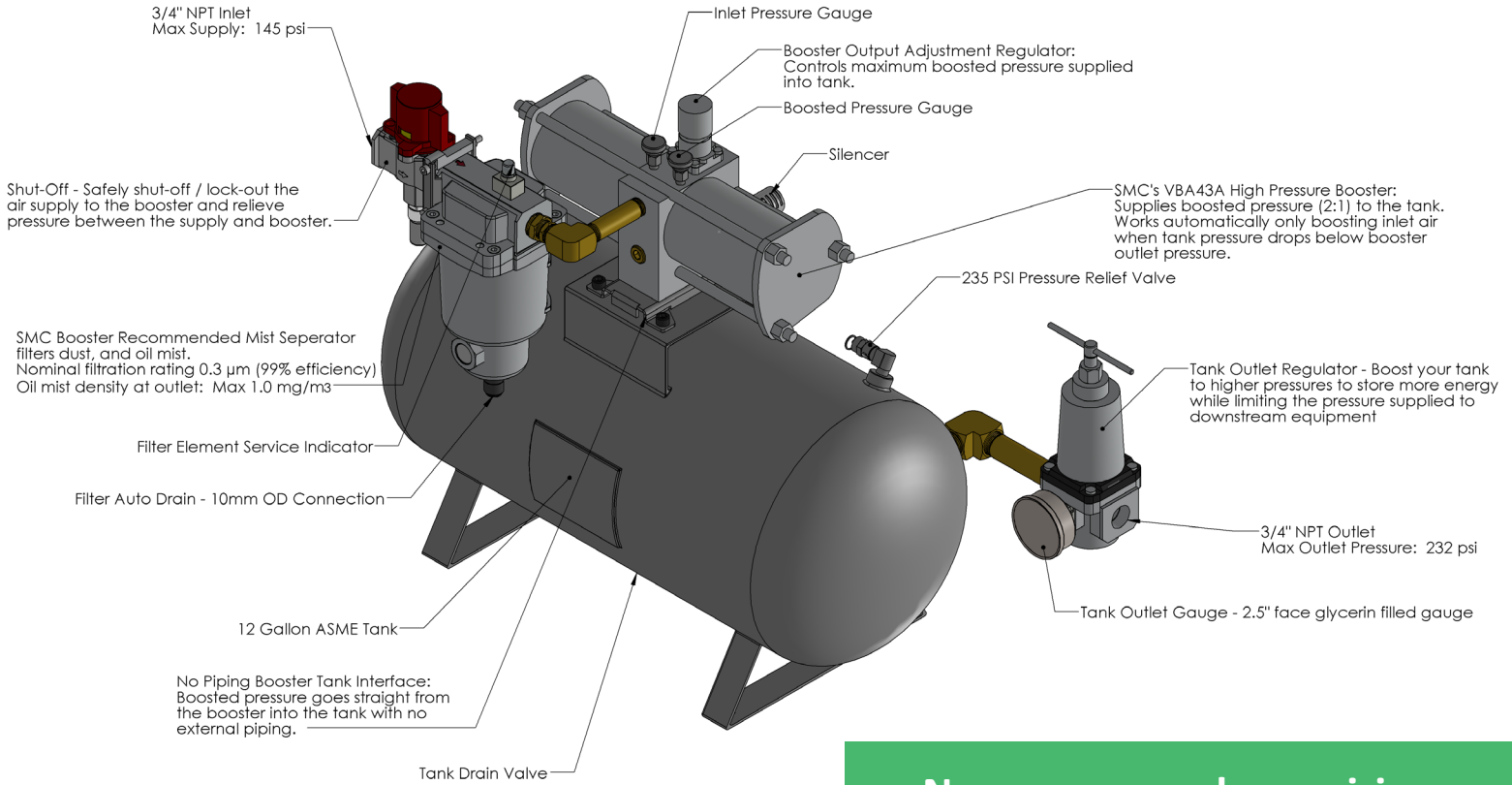

VBA43A Specifications

Fluid	Compressed Air
Pressure Increase Ratio	Twice
Max Booster Flow Rate**	1600 L/min(ANR) - 56.5 SCFM
Supply Pressure Range	15 to 145 psi
Set Pressure Range	29 to 232 psi
Proof Pressure	348 psi
Ambient and Fluid Temperature	3 35.6 to 122°F (No freezing)

**Flow rate at IN=OUT=72.5psi. The pressure varies by operating conditions

- No power supply or wiring needed
- Low heat generation
- Easy Installation
- Air only operation
- Fully assembled and tested



Toll Free: 1-800-222-2903
Local: 704-875-1611

<http://www.scotteq.com>

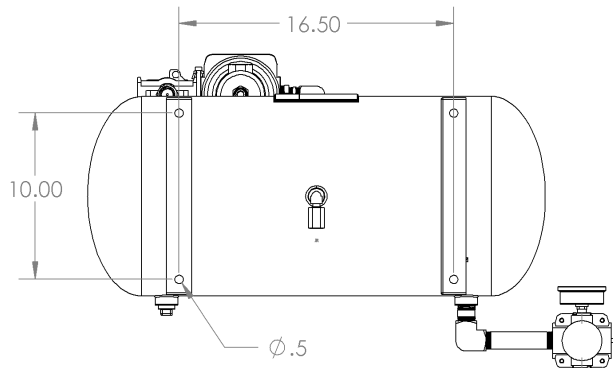
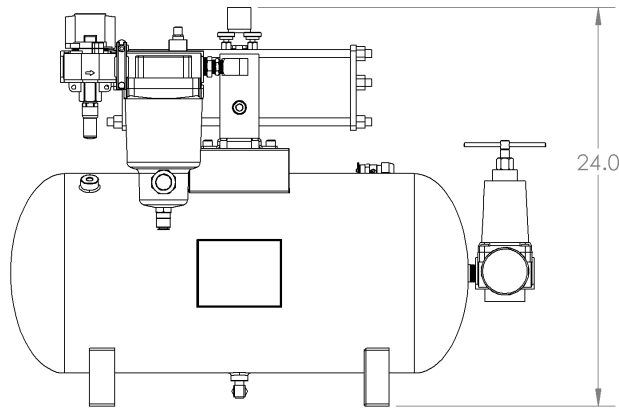
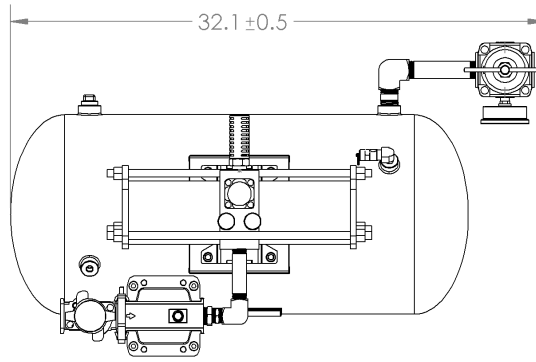
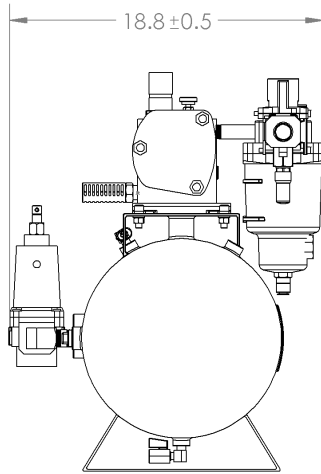

Flow-rate Characteristics

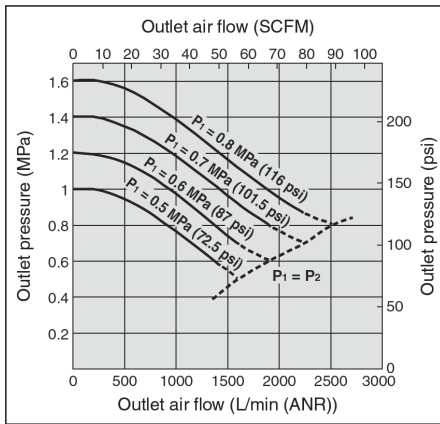

Pressure Characteristics

Inlet pressure: 0.7 MPa (101.5 psi)
 Outlet pressure: 1.0 MPa (145 psi) (Representative value)
 Flow rate: 20 L/min [ANR] (0.71 SCFM)

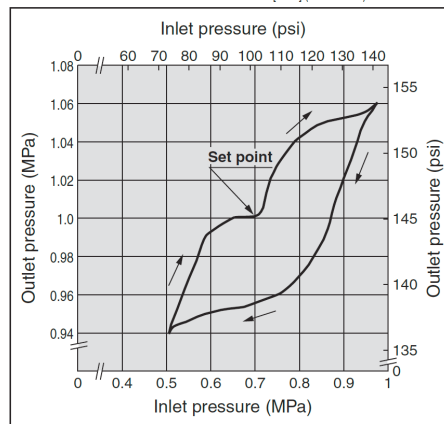

Charge Characteristics

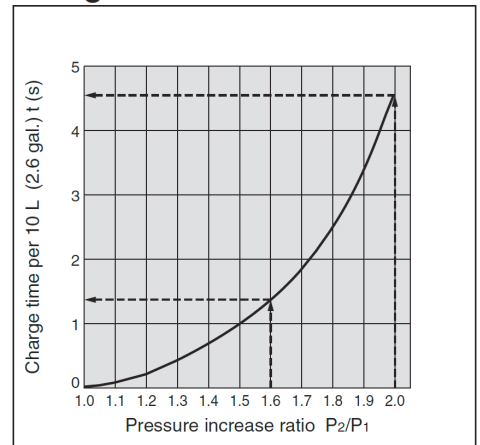

Part Number: SA-VBA43A-T04GN-Z-VBAT45HP-SV-MS-R

Toll Free: 1-800-222-2903
 Local: 704-875-1611

<http://www.scotteq.com>

